

TRUSTED PARTNER OF



SMOKE DAMPERS

VU120

Rectangular smoke control damper.

Suitable for installation in
smoke control systems in
multiple compartments.



Conforms with:



Standard EN 12101-8

Tested to EN 1366-10 (-500Pa)

Classified under EN 13501-4

Explanation of the abbreviations and pictograms

Wn = nominal width
 Hn = nominal height
 Sn = free air passage
 E = integrity
 I = thermal insulation
 S = smoke leakage
 60/120 = fire resistance time
 Pa = pascal
 o -> i = meets the criteria from the outside (o) to the inside (i)
 i <-> o = fire side not important
 AA = automatic activation
 multi = multi compartment
 1500 = pressure level 3 (1500Pa)
 ved = vertical duct

hod = horizontal duct
 vew = vertical wall penetration
 V = volt
 W = watt
 V AC = Volt alternating current
 V DC = Volt direct current
 E.TELE = power supply magnet
 E.ALIM = power supply motor
 Auto = automatic
 Tele = remote controlled
 Pnom = nominal capacity
 Pmax = maximum capacity
 DAS MOD = modular product
 OP = option (delivered with the product)

KIT = kit (delivered separately for repair or upgrade)
 PG = connection flange to the duct
 GKB (type A) / GKF (type F): "GKB" stands for standard plasterboards (type A according to EN 520) while "GKF" plasterboards offer a higher fire resistance for a similar plate thickness (type F according to EN 520)
 Cal-Sil = calcium silicate
 ζ [-] = pressure loss coefficient
 Q = air flow
 ΔP = static pressure drop
 v = air speed in the duct
 Lwa = A-weighted sound power level
 ME = motorised
 H = habitat

	optimal free air passage and minimal pressure loss		superior air tightness (tested at 1500 Pa)
	intermediate dimensions on request		

TRUSTED PARTNER OF



SMOKE DAMPERS

VU120

Rectangular smoke control damper.

CONTENTS

Declaration of performance	4
Product presentation VU120	5
Evolution - kits	6
Flange types - at the time of order	8
Storage and handling	10
Installation	11
Operation and mechanisms	20
Electrical connection	24
Weights	26
Approvals and certificates	29

DECLARATION OF PERFORMANCE

CE_DOP_Rf-t_V22_EN J-11/2019

1. Unique identification code of the product-type:	VU120
2. Intended use/s:	Smoke control damper to be used in smoke control systems, in multi-compartment applications.
3. Manufacturer:	Rf-Technologies NV, Lange Ambachtstraat 40, B-9860 Oosterzele
4. System/s of AVCP:	System 1
5. Harmonised standard / European Assessment Document; notified body / European Technical Assessment, Technical Assessment Body, notified body;	EN 12101-8:2011, Efectis with identification number 1812; Efectis - 1812-CPR-1595
6. Declared performance according to EN 12101-8:2011	(fire resistance according to EN 1366-10, classification according to EN 13501-4)

Essential characteristics	Shaft type	Shaft	Sealing	Installation	Performance Classification
Range 200x200 mm ≤ VU120+MANF/BLE + grill ≤ 1200x800 mm; 1000x1000. 200x200 mm ≤ VU120+NF/SF + grill ≤ 1200x650 mm; 950x750 mm	Vertical / horizontal shaft	Promatect L500 ≥ 30 mm Geoflam ≥ 30 mm Geotec ≥ 30 mm Techniver ≥ 35 mm Glasroc F V500 ≥ 35 mm Exthamat ≥ 25 mm Dese耐火 ≥ 25 mm HD Promatect L500 ≥ 40 mm Geoflam ≥ 35 mm Techniver ≥ 45 mm Exthamat ≥ 30 mm Dese耐火 ≥ 25 mm THD Reinforced concrete (≥ 2150 kg/m³) ≥ 70 mm	Gap between duct and damper (≤ 6 mm) sealed with refractory kit (on a depth ≥ 105 mm) Gap between duct and damper (≤ 80 mm) sealed with refractory kit (on a depth ≥ 105 mm) Gap between duct and damper (≤ 80 mm) sealed with refractory kit (on a depth ≥ 105 mm) Gap between duct and damper (≤ 6 mm) sealed with refractory kit (on a depth ≥ 105 mm) Gap between duct and damper (≤ 6 mm) sealed with refractory kit (on a depth ≥ 105 mm) Gap between duct and damper (≤ 80 mm) sealed with refractory kit (on a depth ≥ 105 mm) Gap between duct and damper (≤ 80 mm) sealed with refractory kit (on a depth ≥ 105 mm) Gap between duct and damper (≤ 6 mm) sealed with refractory kit (on a depth ≥ 105 mm) Gap between duct and damper (≤ 6 mm) sealed with refractory kit (on a depth ≥ 105 mm) Mortar Gap between duct and damper (≤ 6 mm) sealed with refractory kit (on a depth ≥ 105 mm) Gap between duct and damper (≤ 80 mm) sealed with refractory kit (on a depth ≥ 105 mm) Gap between duct and damper (≤ 80 mm) sealed with refractory kit (on a depth ≥ 105 mm) Gap between duct and damper (≤ 6 mm) sealed with refractory kit (on a depth ≥ 105 mm) Gap between duct and damper (≤ 6 mm) sealed with refractory kit (on a depth ≥ 105 mm) Gap between duct and damper (≤ 80 mm) sealed with refractory kit (on a depth ≥ 105 mm) Gap between duct and damper (≤ 80 mm) sealed with refractory kit (on a depth ≥ 105 mm) Mortar	1	E160 (V _{ed} , h _{ed} , i ↔ o) S 1500 AA multi
	Vertical / horizontal shaft	Promatect L500 ≥ 40 mm Geoflam ≥ 35 mm Techniver ≥ 45 mm Exthamat ≥ 30 mm Dese耐火 ≥ 25 mm THD Reinforced concrete (≥ 2150 kg/m³) ≥ 70 mm	Gap between duct and damper (≤ 6 mm) sealed with refractory kit (on a depth ≥ 105 mm) Gap between duct and damper (≤ 80 mm) sealed with refractory kit (on a depth ≥ 105 mm) Gap between duct and damper (≤ 80 mm) sealed with refractory kit (on a depth ≥ 105 mm) Gap between duct and damper (≤ 6 mm) sealed with refractory kit (on a depth ≥ 105 mm) Gap between duct and damper (≤ 6 mm) sealed with refractory kit (on a depth ≥ 105 mm) Mortar Gap between duct and damper (≤ 6 mm) sealed with refractory kit (on a depth ≥ 105 mm) Gap between duct and damper (≤ 80 mm) sealed with refractory kit (on a depth ≥ 105 mm) Gap between duct and damper (≤ 80 mm) sealed with refractory kit (on a depth ≥ 105 mm) Gap between duct and damper (≤ 6 mm) sealed with refractory kit (on a depth ≥ 105 mm) Gap between duct and damper (≤ 6 mm) sealed with refractory kit (on a depth ≥ 105 mm) Gap between duct and damper (≤ 80 mm) sealed with refractory kit (on a depth ≥ 105 mm) Gap between duct and damper (≤ 80 mm) sealed with refractory kit (on a depth ≥ 105 mm) Mortar	1	E190 (V _{ed} , h _{ed} , i ↔ o) S 1500 AA multi
	Vertical shaft	Promatect L500 ≥ 50 mm Geoflam ≥ 45 mm Geoflam Light ≥ 35 mm Geotec ≥ 45 mm Techniver ≥ 50 mm Glasroc F V500 ≥ 50 mm Exthamat ≥ 35 mm Dese耐火 ≥ 35 mm HD Dese耐火 STR ≥ 25 mm	Gap between duct and damper (≤ 6 mm) sealed with refractory kit (on a depth ≥ 105 mm) Gap between duct and damper (≤ 80 mm) sealed with refractory kit (on a depth ≥ 105 mm) Gap between duct and damper (≤ 80 mm) sealed with refractory kit (on a depth ≥ 105 mm) Gap between duct and damper (≤ 6 mm) sealed with refractory kit (on a depth ≥ 105 mm) Gap between duct and damper (≤ 6 mm) sealed with refractory kit (on a depth ≥ 105 mm) Mortar Gap between duct and damper (≤ 6 mm) sealed with refractory kit (on a depth ≥ 105 mm) Gap between duct and damper (≤ 80 mm) sealed with refractory kit (on a depth ≥ 105 mm) Gap between duct and damper (≤ 80 mm) sealed with refractory kit (on a depth ≥ 105 mm) Gap between duct and damper (≤ 6 mm) sealed with refractory kit (on a depth ≥ 105 mm) Gap between duct and damper (≤ 6 mm) sealed with refractory kit (on a depth ≥ 105 mm) Gap between duct and damper (≤ 80 mm) sealed with refractory kit (on a depth ≥ 105 mm) Gap between duct and damper (≤ 80 mm) sealed with refractory kit (on a depth ≥ 105 mm) Mortar	1	E190 (V _{ed} , i ↔ o) S 1500 AA multi E1120 (V _{ed} , h _{ed} , i ↔ o) S 1500 AA multi
	Vertical / horizontal shaft	Promatect L500 ≥ 50 mm Geoflam ≥ 45 mm Geoflam Light ≥ 35 mm Geotec ≥ 45 mm Techniver ≥ 50 mm Glasroc F V500 ≥ 50 mm Exthamat ≥ 35 mm Dese耐火 ≥ 35 mm HD Dese耐火 STR ≥ 25 mm	Gap between duct and damper (≤ 6 mm) sealed with refractory kit (on a depth ≥ 105 mm) Gap between duct and damper (≤ 80 mm) sealed with refractory kit (on a depth ≥ 105 mm) Gap between duct and damper (≤ 80 mm) sealed with refractory kit (on a depth ≥ 105 mm) Gap between duct and damper (≤ 6 mm) sealed with refractory kit (on a depth ≥ 105 mm) Gap between duct and damper (≤ 6 mm) sealed with refractory kit (on a depth ≥ 105 mm) Mortar Gap between duct and damper (≤ 6 mm) sealed with refractory kit (on a depth ≥ 105 mm) Gap between duct and damper (≤ 80 mm) sealed with refractory kit (on a depth ≥ 105 mm) Gap between duct and damper (≤ 80 mm) sealed with refractory kit (on a depth ≥ 105 mm) Gap between duct and damper (≤ 6 mm) sealed with refractory kit (on a depth ≥ 105 mm) Gap between duct and damper (≤ 6 mm) sealed with refractory kit (on a depth ≥ 105 mm) Gap between duct and damper (≤ 80 mm) sealed with refractory kit (on a depth ≥ 105 mm) Gap between duct and damper (≤ 80 mm) sealed with refractory kit (on a depth ≥ 105 mm) Mortar	1	E1120 (V _{ed} , i ↔ o) S 1500 AA multi



1	Type of installation: shaft-mounted 0/90°/180°/270°; Minimal distances authorised.
---	--

Nominal activation conditions/sensitivity:	Pass - automatic activation
Response delay (response time): closure time	Pass - automatic activation
Operational reliability: cycling	Belimo NF - 300 cycles (with load); Belimo SF - 300 cycles (with load); MANF - 10000 cycles (C10000) (no load)
Durability of response delay:	Pass
Durability of operational reliability:	Pass
High operational temperature (HOT 400/30):	NPD (no performance determined)

The performance of the product identified above is in conformity with the set of declared performance/s. This declaration of performance is issued, in accordance with Regulation (EU) No 305/2011, under the sole responsibility of the manufacturer identified above.

Signed for and on behalf of the manufacturer by:
Mathieu Steenland, Technical Manager

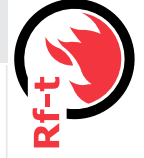
 Oosterzele, 11/2019



Product presentation VU120

The rectangular VU120 smoke evacuation damper is noted for its superior airtight properties. It was developed in accordance with the European product standard EN 12101-8 and tested according to the EN 1366-10 standard. The VU120 offers a fire resistance up to 120 minutes, and ensures minimum pressure loss.

Smoke evacuation shutters and dampers are suitable for use in ventilating protected lobbies, venting to shafts either naturally or mechanically. They open to evacuate smoke in emergency situations whilst maintaining fire resistant integrity in standby position.

- ✓ superior air tightness (tested at 1500 Pa)
- ✓ optimal free air passage and minimal pressure loss



- tested according to EN 1366-10
- compliant with EN 12101-8
- approved for installation in calcium-silicate, 'Staff' and concrete shafts
- maintenance-free
- for indoor use
- intermediate dimensions on request

1. connection flange PG30 on the side of the mechanism
2. simple flat finish (PS) at the shaft side
3. casing made of refractory material
4. damper blade
5. operating mechanism
6. sealing and blade bumper
7. intumescent strip
8. transmission with locking (open/closed)
9. product identification

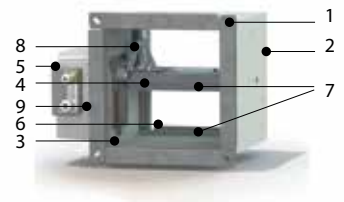

Range and dimensions VU120

Wn/Hn per step of 50 mm; intermediate dimensions are subject to extra cost (heights between ≥ 275 and ≤ 299 mm are not possible). Exceeding blade: X = on the mechanism side, Y = on the wall side

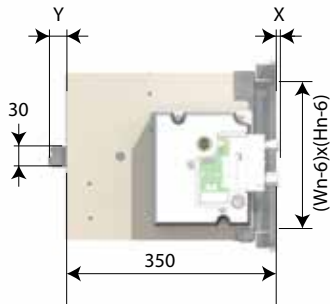

Hn (mm)	200	250	300	350	400	450	500	550	600	650	700	750	800	850	900	950	1000
x	-	-	-	-	-	-	-	9	34	59	84	109	134	159	184	209	234
y	4	29	54	79	104	129	154	179	204	229	254	279	304	329	354	379	404

	IV	V
(Wn x Hn) mm	200x200	1000x1000 1200x800

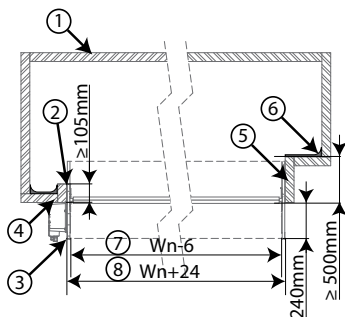

1. Shaft wall
2. Sealing
3. PG30 flange
4. Mounting without shaft extension
5. Mounting with shaft extension
6. Fibrous plaster filling (only for GEOFLAM Light)
7. Inside dimensions casing (Wn-6) x (Hn-6)
8. Outside dimensions casing (Wn+24) x (Hn+24)

Hn < 300 mm

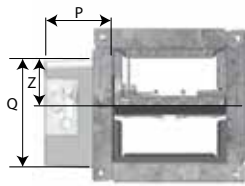

Hn ≥ 300 mm

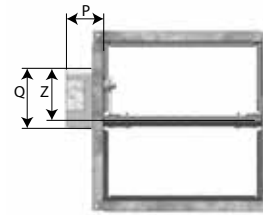

	MANF	NF	SF	BLE
P	115	85	85	110
Q	190	100	100	110
Z	85	105	105	85

	MANF	NF	SF	BLE
P	115	85	85	110
Q	190	100	100	110
Z	180	105	105	180

Evolution - kits



KITS BLE24

BLE 24V actuator for smoke control dampers



KITS BLE24-ST

BLE 24V actuator for smoke control dampers with plug (ST)



KITS BLE230

BLE 230V actuator for smoke control dampers



KITS NF24

Actuator NF 24V



KITS SF24

Actuator SF 24V







KITS NF230

Actuator NF 230V



KITS SF230

Actuator SF 230V

	KITS NF/SF-VD	NF/SF-VD module (NF24/SF24: 24-48 V DC). Only for France.
	KITS MANF EVO VD24 FDCU	Upgradeable remote controlled unlocking mechanism with natural magnet 24 V DC + FDCU
	KITS MANF EVO VD48 FDCU	Upgradeable remote controlled unlocking mechanism with natural magnet 48 V DC + FDCU
	KITS MANF EVO VM24 FDCU	Upgradeable remote controlled unlocking mechanism with electromagnet 24 V DC + FDCU
	KITS MANF EVO VM48 FDCU	Upgradeable remote controlled unlocking mechanism with electromagnet 48 V DC + FDCU
	KITS VD24 MAN EVO FDCU	Natural magnet 24 V DC + FDCU
	KITS VD48 MAN EVO FDCU	Natural magnet 48 V DC + FDCU
	KITS VM24 MAN EVO FDCU	Electromagnet 24 V DC + FDCU
	KITS VM48 MAN EVO FDCU	Electromagnet 48 V DC + FDCU
	KITS FDCU MAN	Limit switch 'open/closed'

Flange types - at the time of order



KITS FDCB MAN

Auxiliary limit switch 'open/closed'



KITS ME MANF

Resetting motor ME 24V/48V



MECT

Testbox for mechanisms 24/48 V (magnet, motor, beginning and end of range switches)

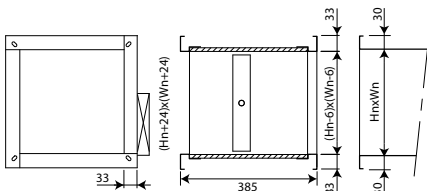

PG30

Alternative connection to standard PS at the shaft side: PG30 connection to ducts with 30 mm flanges, with elliptical holes $\varnothing 8,5 \times 16$ mm.

Flange types - at the time of order

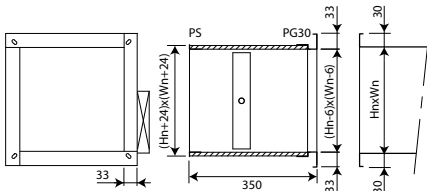

PS

No connection (standard connection shaft side). Also possible on shaft side: PG30, PG20, PG40, PM.

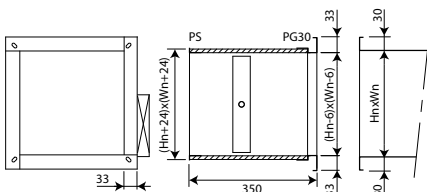

PG30

Connection to ducts with 30 mm flanges (either by sliding profile or with bolts). Also possible on shaft side instead of PS connection (at order time). Elliptical holes $\varnothing 8,5 \times 16$ mm.

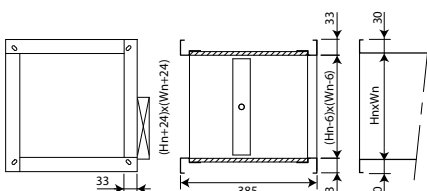

PG302

Alternative connection to standard PS at the shaft side: PG30 connection to ducts with 30 mm flanges, with elliptical holes $\varnothing 8,5 \times 16$ mm.

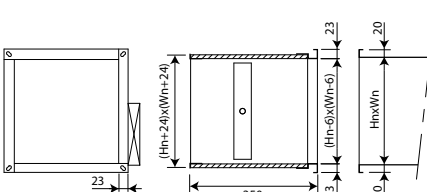

PG20

Connection to ducts with 20 mm flanges, elliptical holes $\varnothing 6,5 \times 16$ mm. Also possible on shaft side instead of PS connection (at order time).

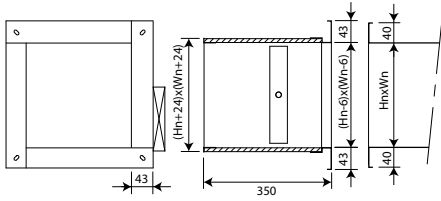

PG40

Connection to ducts with 40mm flanges, elliptical holes $\varnothing 8,5 \times 16$ mm. Also possible on shaft side instead of PS / PG30 connection (at order time).

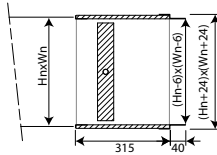

PM

Connection to ducts by insertion. This type of frame is used in case of lack of space for a standard PG30 frame. Possible on mechanism side instead of PG30 connection (at order time).



PBJ

Circular connection with rubber sealing ring on a rectangular damper with PG20 flange. Possible on mechanism side instead of PG30 connection (at order time).

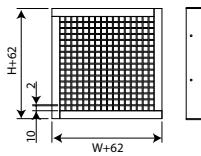

**PPT
(+PG3V)**

Grill, very well suited as protection grill on the end piece of a duct system (PG3V + PPT). Possible on mechanism side instead of PG30 connection (at order time).

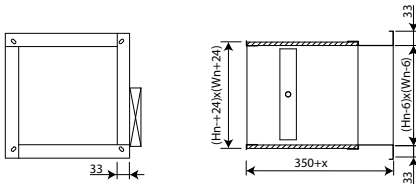

PG3V

Elongated frame to avoid the damper blade from exceeding the tunnel. Connection to ducts with 30 mm flanges. The four corners of the frame are provided with elliptical holes $\varnothing 8,5 \times 16$ mm. Maximum extension (in steps of 50 mm) on 1 side = 500 mm. Possible on mechanism side instead of PG30 connection (at order time).

Storage and handling

As this product is a safety element, it should be stored and handled with care.

Avoid:

- any kind of impact or damage
- contact with water
- deformation of the casing

It is recommended:

- to unload in a dry area
- not to flip or roll the product to move it
- not to use the damper as a scaffold, working table, etc.
- not to store smaller dampers inside larger ones

Installation

General points

- The installation must comply with the installation manual and the classification report.
- The installation of the shaft must comply with the classification report delivered by the shaft manufacturer.
- Axis orientation: see the declaration of performance.
- Avoid the obstruction of adjoining shafts.
- Verify if the blade can move freely.
- Rf-t smoke dampers may be applied to ducts that have been tested according to EN 1366-8 and EN 1366-9 as appropriate, constructed from similar materials with a fire resistance, thickness and density equal or superior to these of the tested materials.
 - ▲ Caution: when fitting, the product should be handled with care and remain protected from any sealing products.
 - ▲ Caution: before putting the installation into operation, clean off all the dust and dirt.
 - ▲ Caution: bear in mind the blade's clearance inside the smoke evacuation duct.

Position in the shaft

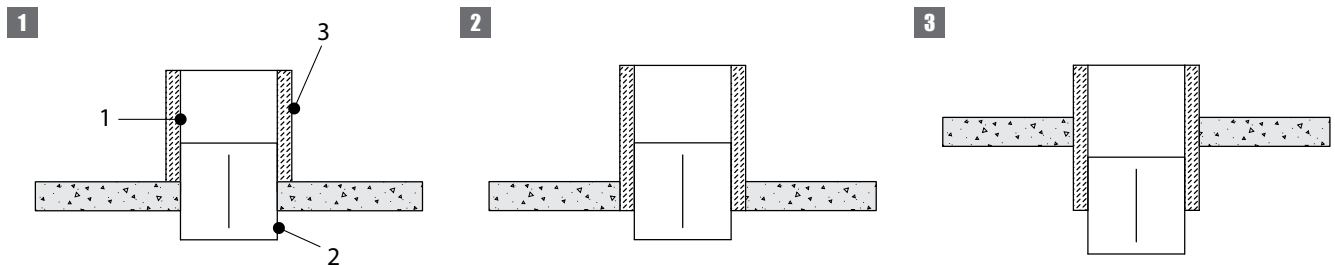

1. Shaft - 2. Smoke evacuation damper - 3. Thermal insulation ensured by the shaft

Installation in shaft - cross section view

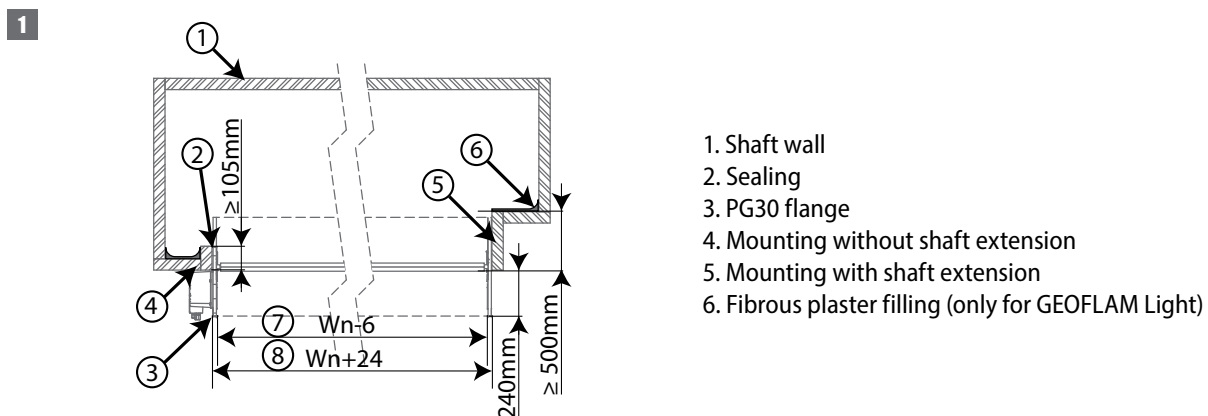

1. Shaft wall
2. Sealing
3. PG30 flange
4. Mounting without shaft extension
5. Mounting with shaft extension
6. Fibrous plaster filling (only for GEOFLAM Light)

Installation into horizontal or vertical shaft PROMATECT L500

The product was tested and approved in:

Range	Shaft type	Sealing	Classification
200x200 mm ≤ VU120+MANF/BLE + grill ≤ 1200x800 mm; 1000x1000. 200x200 mm ≤ VU120+NF/SF + grill ≤ 1200x650 mm; 950x750 mm	Vertical / horizontal shaft	Promatect L500 ≥ 30 mm	EI 60 (v _{ed} h _{od} i ↔ o) S 1500 AA multi
200x200 mm ≤ VU120+MANF/BLE + grill ≤ 1200x800 mm; 1000x1000. 200x200 mm ≤ VU120+NF/SF + grill ≤ 1200x650 mm; 950x750 mm	Vertical / horizontal shaft	Promatect L500 ≥ 40 mm	EI 90 (v _{ed} h _{od} i ↔ o) S 1500 AA multi
200x200 mm ≤ VU120+MANF/BLE + grill ≤ 1200x800 mm; 1000x1000. 200x200 mm ≤ VU120+NF/SF + grill ≤ 1200x650 mm; 950x750 mm	Vertical / horizontal shaft	Promatect L500 ≥ 50 mm	EI 120 (v _{ed} h _{od} i ↔ o) S 1500 AA multi

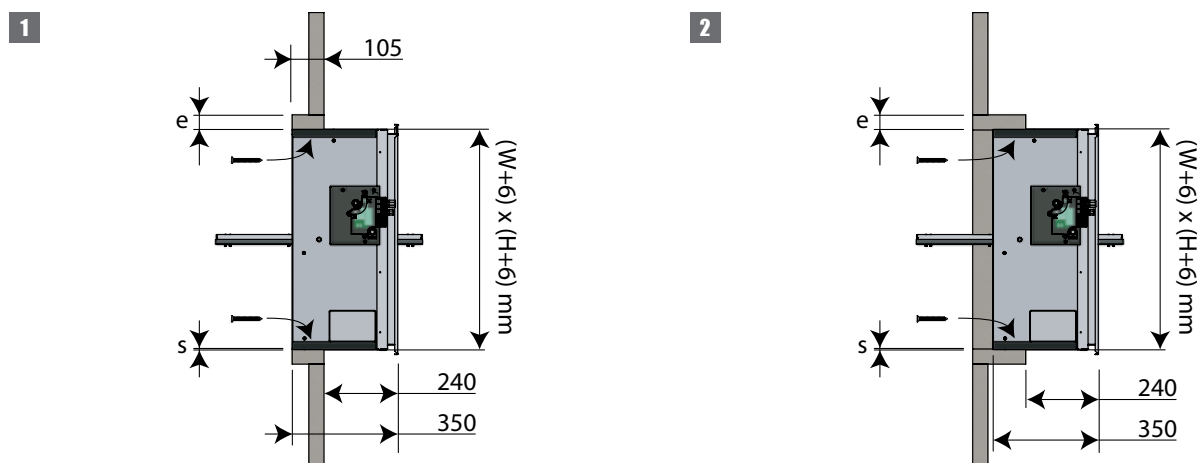

1. Make an opening with dimensions (W+A) x (H+A) mm.

A = 2 x thickness sleeve (e) + 6 mm.

Fit a sleeve of the same type and thickness of the duct (thickness e) of minimum 105 mm deep in the opening.

Fix the sleeve to the shaft wall.

First coat the opening with Promacol S.

Position the damper in the opening and fix the damper using

12 screws Ø5x60 (horizontal shaft) or using 10 screws Ø5x60

(vertical shaft).

⚠ Caution: make sure that the bolts don't exceed the sleeve's thickness!

The seal between the casing and the shaft (S) must be completely filled with refractory coating (type Promacol S).

Support the tunnel or tighten the blade in its closed position to prevent deformation of the casing during drying of the sealing material.

Fix the grill to the flange using glue type Polyflex.

Check the movement of the damper blade.

Run a test on the mechanism of the damper.

Installation into horizontal or vertical shaft GEOFLAM (LIGHT)

The product was tested and approved in:

Range	Shaft type	Sealing	Classification
200x200 mm ≤ VU120+MANF/BLE + grill ≤ 1200x800 mm; 1000x1000. 200x200 mm ≤ VU120+NF/SF + grill ≤ 1200x650 mm; 950x750 mm	Vertical / horizontal shaft	Geoflam ≥ 30 mm	El 60 (v _{ed} h _{od} i ↔ o) S 1500 AA multi
200x200 mm ≤ VU120+MANF/BLE + grill ≤ 1200x800 mm; 1000x1000. 200x200 mm ≤ VU120+NF/SF + grill ≤ 1200x650 mm; 950x750 mm	Vertical / horizontal shaft	Geoflam ≥ 35 mm	El 90 (v _{ed} h _{od} i ↔ o) S 1500 AA multi
200x200 mm ≤ VU120+MANF/BLE + grill ≤ 1200x800 mm; 1000x1000. 200x200 mm ≤ VU120+NF/SF + grill ≤ 1200x650 mm; 950x750 mm	Vertical / horizontal shaft	Geoflam ≥ 45 mm	El 120 (v _{ed} h _{od} i ↔ o) S 1500 AA multi
200x200 mm ≤ VU120+MANF/BLE + grill ≤ 1200x800 mm; 1000x1000. 200x200 mm ≤ VU120+NF/SF + grill ≤ 1200x650 mm; 950x750 mm	Vertical / horizontal shaft	Geoflam Light ≥ 35 mm	El 120 (v _{ed} h _{od} i ↔ o) S 1500 AA multi

1

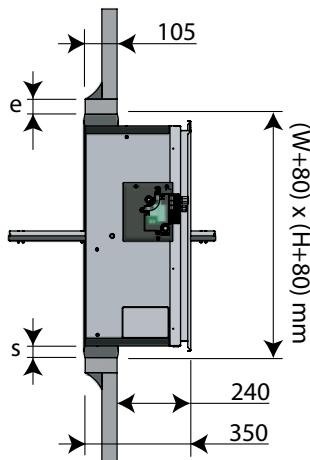

2

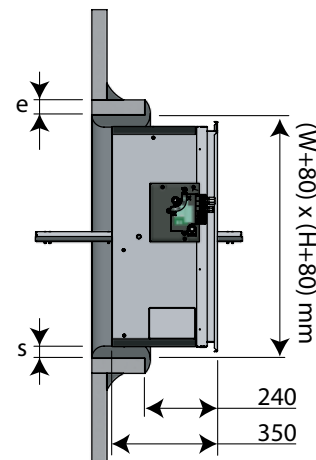

1. Make an opening with dimensions $(W+80) \times (H+80)$ mm.
Fit a sleeve of the same type and thickness of the duct (thickness e) of minimum 105 mm deep in the opening.
Seal the joints between uprights and cross pieces and between the lining and the wall with vegetable fibre caulking and plaster.
The seal between the casing and the shaft (S) must be completely filled with fibre reinforced plaster. Support the tunnel or tighten the blade in its closed position to prevent deformation of the casing during drying of the sealing material.
Fix the grill to the flange using glue type Polyflex.
Check the movement of the damper blade.
Run a test on the mechanism of the damper.

Installation into horizontal or vertical shaft GEOTEC

The product was tested and approved in:

Range	Shaft type	Sealing	Classification
200x200 mm ≤ VU120+MANF/BLE + grill ≤ 1200x800 mm; 1000x1000. 200x200 mm ≤ VU120+NF/SF + grill ≤ 1200x650 mm; 950x750 mm	Vertical / horizontal shaft	Geotec ≥ 30 mm	EI 60 (v _{ed} h _{od} i ↔ o) S 1500 AA multi
200x200 mm ≤ VU120+MANF/BLE + grill ≤ 1200x800 mm; 1000x1000. 200x200 mm ≤ VU120+NF/SF + grill ≤ 1200x650 mm; 950x750 mm	Vertical / horizontal shaft	Geotec ≥ 45 mm	EI 120 (v _{ed} h _{od} i ↔ o) S 1500 AA multi

1

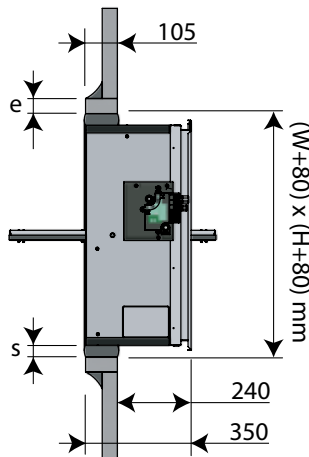

2

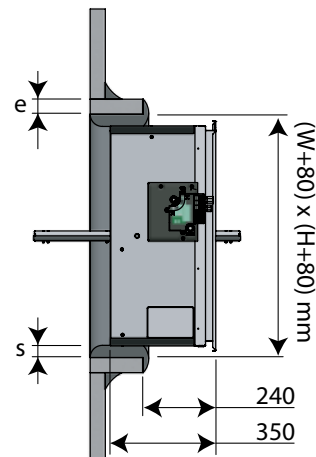

1. In case of fastening with glue and screws:

Make an opening with dimensions $(W+6) \times (H+6)$ mm.

Fit a sleeve of the same type and thickness of the duct (thickness e) of minimum 105 mm deep in the opening.

Fix the sleeve to the shaft wall.

Mount the damper in the opening.

The seal between the casing and the shaft (S) must be completely filled with fibre reinforced plaster. Support the tunnel or tighten the blade in its closed position to prevent deformation of the casing during drying of the sealing material.

Fix the grill to the flange using glue type Polyflex.

Check the movement of the damper blade.

Run a test on the mechanism of the damper.

In case of sealing with fibrous plaster:

Make an opening with dimensions $(W+80) \times (H+80)$ mm.

In case of Geotec you can also assemble the sleeve with glue and screws $\varnothing 5 \times (2 \times e)$ mm and affix the assembled sleeve to the shaft wall with glue and screws $\varnothing 5 \times (2 \times e)$ mm every 100 mm.

Installation into horizontal or vertical shaft TECNIVER

The product was tested and approved in:

Range	Shaft type	Sealing	Classification
200x200 mm ≤ VU120+MANF/BLE + grill ≤ 1200x800 mm; 1000x1000. 200x200 mm ≤ VU120+NF/SF + grill ≤ 1200x650 mm; 950x750 mm	Vertical / horizontal shaft	Tecniver ≥ 35 mm	EI 60 (v _{ed} h _{od} i ↔ o) S 1500 AA multi
200x200 mm ≤ VU120+MANF/BLE + grill ≤ 1200x800 mm; 1000x1000. 200x200 mm ≤ VU120+NF/SF + grill ≤ 1200x650 mm; 950x750 mm	Vertical / horizontal shaft	Tecniver ≥ 45 mm	EI 90 (v _{ed} h _{od} i ↔ o) S 1500 AA multi
200x200 mm ≤ VU120+MANF/BLE + grill ≤ 1200x800 mm; 1000x1000. 200x200 mm ≤ VU120+NF/SF + grill ≤ 1200x650 mm; 950x750 mm	Vertical / horizontal shaft	Tecniver ≥ 50 mm	EI 120 (v _{ed} h _{od} i ↔ o) S 1500 AA multi

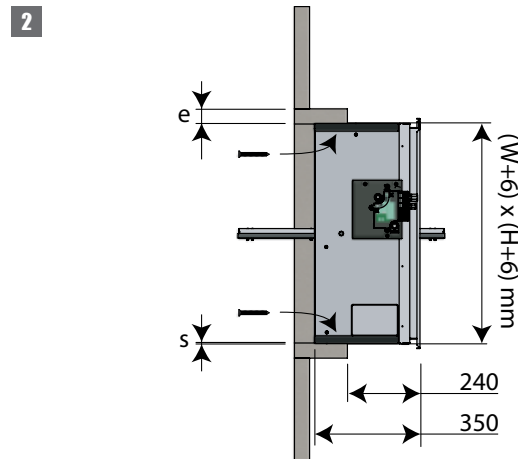
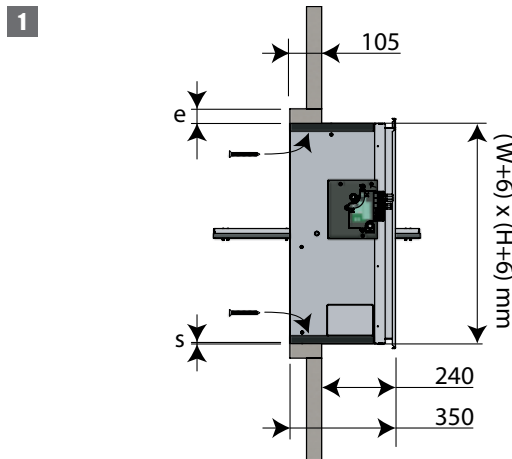

1. Make an opening with dimensions $(W+A) \times (H+A)$ mm.

$A = 2 \times$ thickness sleeve (e) + 6 mm.

Fit a sleeve of the same type and thickness of the duct (thickness e) of minimum 105 mm deep in the opening.

Fix the sleeve to the shaft wall.

Put glue CF GLUE on the edges of the opening and the uprights and cross pieces.

Position the damper in the opening and fix the damper using 12 screws $\text{Ø}5 \times 60$ (horizontal shaft) or using 10 screws $\text{Ø}5 \times 60$ (vertical shaft).

⚠ Caution: make sure that the bolts don't exceed the sleeve's thickness!

The seal between the casing and the shaft (S) must be completely filled with glue (type type CF glue). Support the tunnel or tighten the blade in its closed position to prevent deformation of the casing during drying of the sealing material.

Fix the grill to the flange using glue type Polyflex.

Check the movement of the damper blade.

Run a test on the mechanism of the damper.

Installation into horizontal or vertical shaft GLASROC F V500

The product was tested and approved in:

Range	Shaft type	Sealing	Classification
200x200 mm ≤ VU120+MANF/BLE + grill ≤ 1200x800 mm; 1000x1000. 200x200 mm ≤ VU120+NF/SF + grill ≤ 1200x650 mm; 950x750 mm	Vertical / horizontal shaft	Glasroc F V500 ≥ 35 mm	Gap between duct and damper (≤ 6 mm) sealed with refractory kit (on a depth ≥ 105 mm) EI 60 (v _{ed} h _{od} i ↔ o) S 1500 AA multi
200x200 mm ≤ VU120+MANF/BLE + grill ≤ 1200x800 mm; 1000x1000. 200x200 mm ≤ VU120+NF/SF + grill ≤ 1200x650 mm; 950x750 mm	Vertical / horizontal shaft	Glasroc F V500 ≥ 50 mm	Gap between duct and damper (≤ 6 mm) sealed with refractory kit (on a depth ≥ 105 mm) EI 120 (v _{ed} h _{od} i ↔ o) S 1500 AA multi

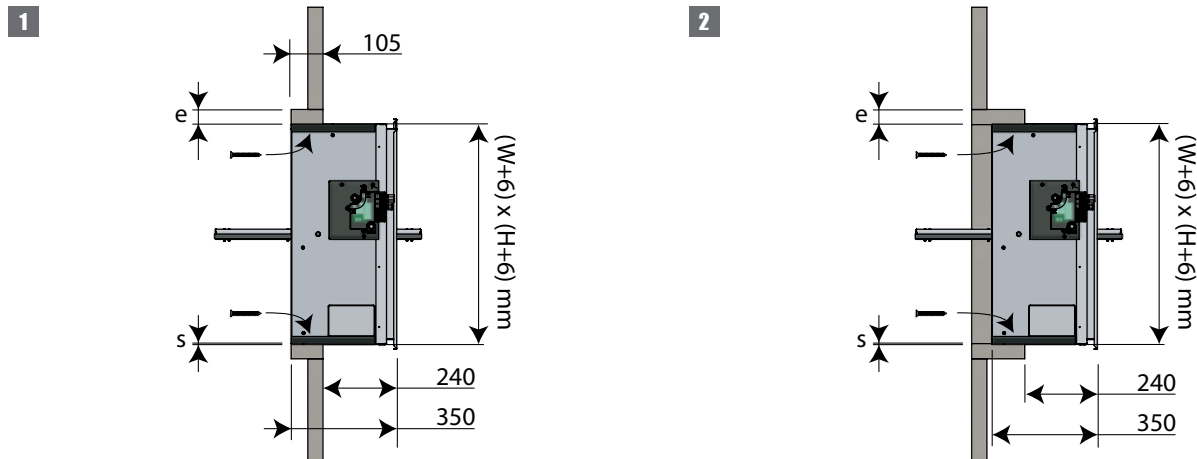

1. Make an opening with dimensions $(W+A) \times (H+A)$ mm.
 $A = 2 \times \text{thickness sleeve } (e) + 6 \text{ mm.}$
 Fit a sleeve of the same type and thickness of the duct
 (thickness e) of minimum 105 mm deep in the opening.
 Fix the sleeve to the shaft wall.
 Put glue GLASROC F V500 on the edges of the opening and the
 uprights and cross pieces.
 Position the damper in the opening and fix the damper using
 12 screws $\varnothing 5 \times 60$ (horizontal shaft) or using 10 screws $\varnothing 5 \times 60$
 (vertical shaft).

⚠ Caution: make sure that the bolts don't exceed the sleeve's
thickness!

- The seal between the casing and the shaft (S) must be
 completely filled with glue (type Glasroc F V500). Support the
 casing or tighten the blade in its closed position to prevent
 deformation of the casing during drying of the sealing material.
 Fix the grill to the flange using glue type Polyflex.
 Check the movement of the damper blade.
 Run a test on the mechanism of the damper.

Installation into horizontal or vertical shaft EXTHAMAT

The product was tested and approved in:

Range	Shaft type	Sealing	Classification
200x200 mm ≤ VU120+MANF/BLE + grill ≤ 1200x800 mm; 1000x1000. 200x200 mm ≤ VU120+NF/SF + grill ≤ 1200x650 mm; 950x750 mm	Vertical / horizontal shaft	Exthamat ≥ 25 mm	EI 60 (v _{ed} h _{od} i ↔ o) S 1500 AA multi
200x200 mm ≤ VU120+MANF/BLE + grill ≤ 1200x800 mm; 1000x1000. 200x200 mm ≤ VU120+NF/SF + grill ≤ 1200x650 mm; 950x750 mm	Vertical / horizontal shaft	Exthamat ≥ 30 mm	EI 90 (v _{ed} h _{od} i ↔ o) S 1500 AA multi
200x200 mm ≤ VU120+MANF/BLE + grill ≤ 1200x800 mm; 1000x1000. 200x200 mm ≤ VU120+NF/SF + grill ≤ 1200x650 mm; 950x750 mm	Vertical / horizontal shaft	Exthamat ≥ 35 mm	EI 120 (v _{ed} h _{od} i ↔ o) S 1500 AA multi

1

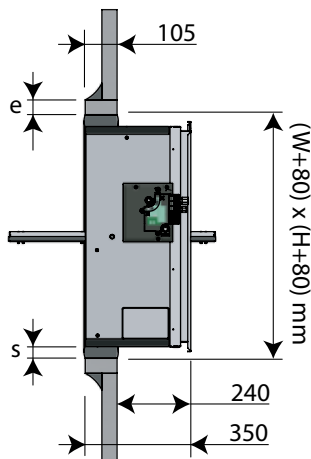

2

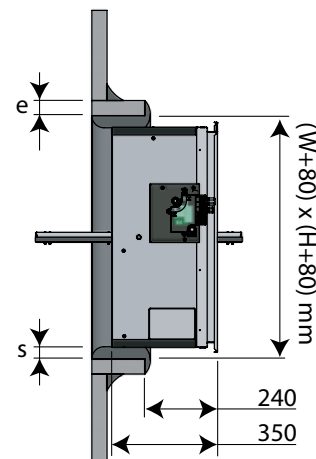

1. Make an opening with dimensions $(W+80) \times (H+80)$ mm.
Fit a sleeve of the same type and thickness of the duct (thickness e) of minimum 105 mm deep in the opening.
Seal the joints between uprights and cross pieces and between the lining and the wall with vegetable fibre caulking and plaster.
The seal between the casing and the shaft (S) must be completely filled with fibre reinforced plaster. Support the tunnel or tighten the blade in its closed position to prevent deformation of the casing during drying of the sealing material.
Fix the grill to the flange using glue type Polyflex.
Check the movement of the damper blade.
Run a test on the mechanism of the damper.

Installation into horizontal or vertical shaft DESENFIRE (HD/THD/STR)

The product was tested and approved in:

Range	Shaft type	Sealing	Classification
200x200 mm ≤ VU120+MANF/BLE + grill ≤ 1200x800 mm; 1000x1000. 200x200 mm ≤ VU120+NF/SF + grill ≤ 1200x650 mm; 950x750 mm	Vertical / horizontal shaft	Desenfire HD ≥ 25 mm	EI 60 (v _{ed} h _{od} i ↔ o) S 1500 AA multi
200x200 mm ≤ VU120+MANF/BLE + grill ≤ 1200x800 mm; 1000x1000. 200x200 mm ≤ VU120+NF/SF + grill ≤ 1200x650 mm; 950x750 mm	Vertical / horizontal shaft	Desenfire HD ≥ 35 mm	EI 120 (v _{ed} h _{od} i ↔ o) S 1500 AA multi
200x200 mm ≤ VU120+MANF/BLE + grill ≤ 1200x800 mm; 1000x1000. 200x200 mm ≤ VU120+NF/SF + grill ≤ 1200x650 mm; 950x750 mm	Vertical / horizontal shaft	Desenfire STR ≥ 25 mm	EI 120 (v _{ed} h _{od} i ↔ o) S 1500 AA multi

1

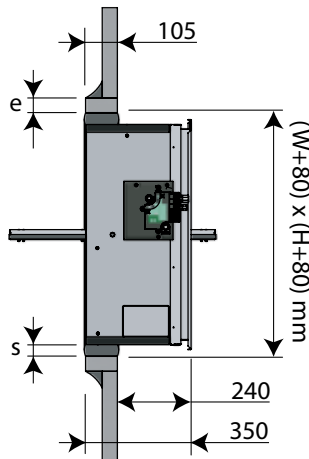

2

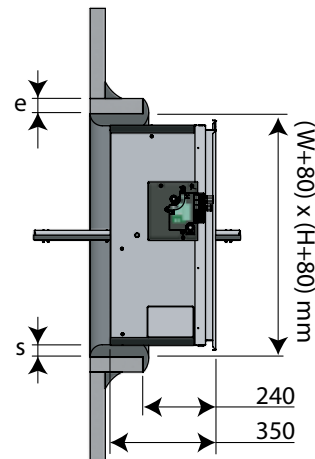

1. Make an opening with dimensions $(W+80) \times (H+80)$ mm.
Fit a sleeve of the same type and thickness of the duct (thickness e) of minimum 105 mm deep in the opening.
Seal the joints between uprights and cross pieces and between the lining and the wall with vegetable fibre caulking and plaster.
The seal between the casing and the shaft (S) must be completely filled with fibre reinforced plaster. Support the tunnel or tighten the blade in its closed position to prevent deformation of the casing during drying of the sealing material.
Fix the grill to the flange using glue type Polyflex.
Check the movement of the damper blade.
Run a test on the mechanism of the damper.

Installation into vertical concrete shaft

The product was tested and approved in:

Range	Shaft type	Sealing	Classification
200x200 mm ≤ VU120+MANF/BLE + grill ≤ 1200x800 mm; 1000x1000. 200x200 mm ≤ VU120+NF/SF + grill ≤ 1200x650 mm; 950x750 mm	Vertical shaft	Mortar	EI 90 (v _{ed} i ↔ o) S 1500 AA multi
200x200 mm ≤ VU120+MANF/BLE + grill ≤ 1200x800 mm; 1000x1000. 200x200 mm ≤ VU120+NF/SF + grill ≤ 1200x650 mm; 950x750 mm	Vertical shaft	Mortar	EI 120 (v _{ed} i ↔ o) S 1500 AA multi

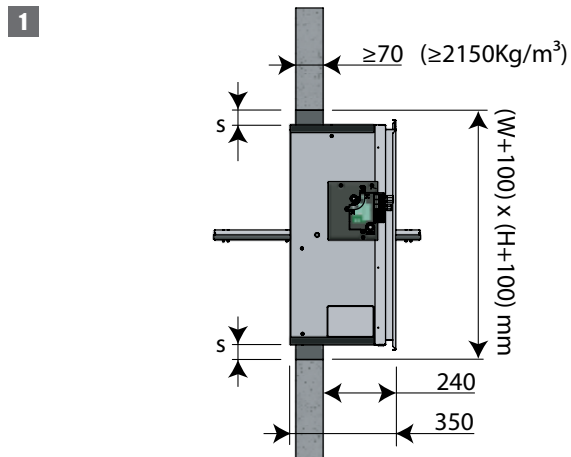

1. Make an opening with dimensions (W+20) x (H+20) mm till (W+100) x (H+100) mm.

Mount the damper in the opening. The joint between the damper and the shaft (S) needs to be filled right across the width of the duct with a standard concrete mortar.

Support the body and block the damper blade in its closed position to prevent deformation of the body during the drying process of the sealing.

Fix the grill to the flange using glue type Polyflex.

Check the movement of the damper blade.

Run a test on the mechanism of the damper.

Installation at minimal distances

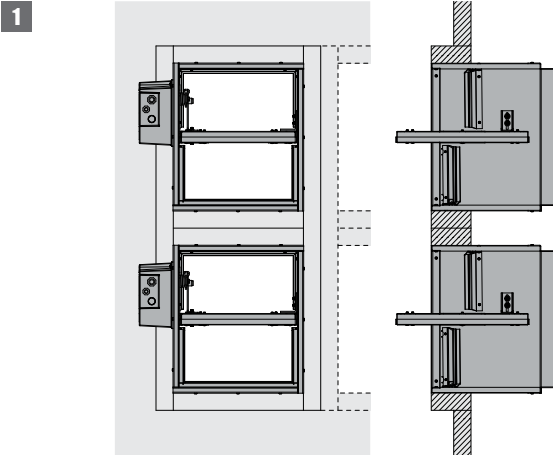

1. The smoke evacuation dampers can be installed at minimal distance on top of or next to each other, if they are mounted in separate sleeves made from the shaft material with the required fire resistance. It is advised not to exceed a 2 x 4 configuration (H x W).

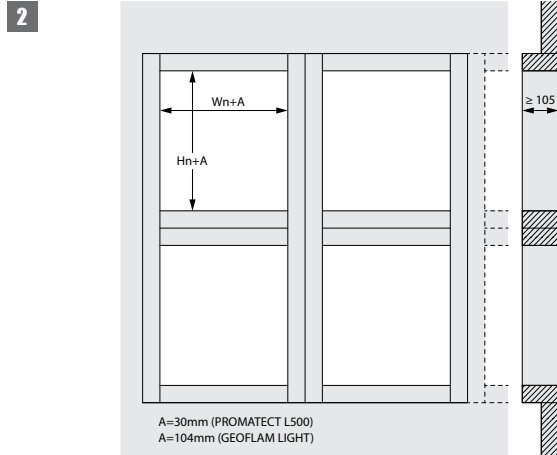

2. In case several smoke evacuation dampers are mounted at a minimal distance, the bearing and reinforcement points of the shaft must be adjusted in proportion to the increased weight. The installation of the shaft must comply with the classification report delivered by the shaft manufacturer.

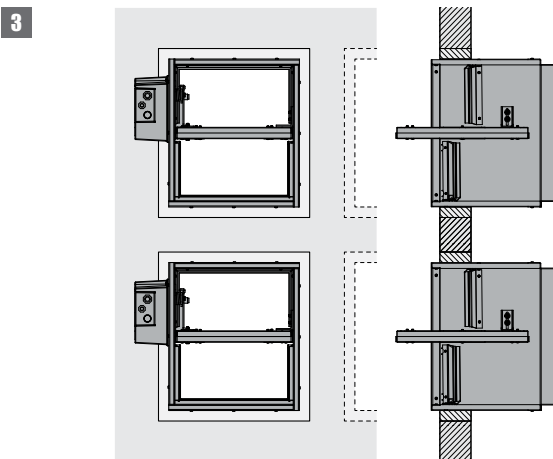

3. When mounting more than 2 smoke evacuation dampers in a concrete shaft, you need to provide a continuous reinforcement in the vertical columns of at least 4 x Ø 8 mm.

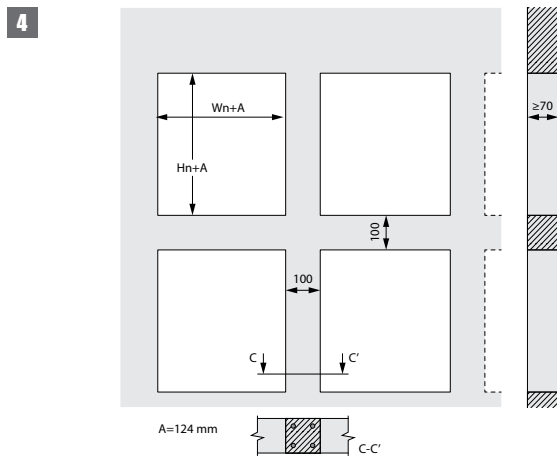

Maintenance

- No specific maintenance required.
- Schedule at least two running visual checks each year.
- Remove dust and all other particles before start-up.
- Follow the local maintenance regulations (i.e. BS9999 Annex V; NF S 61-933) and EN13306.

Operation and mechanisms



MANF Upgradeable remote controlled unlocking mechanism

The unlocking mechanism MANF EVO unlatches the damper blade via remote control by sending an electric impulse (VD) or by interruption (VM) of the magnets power supply. A begin- and end of range switch (FDCU) is standard available. The blade can be reset manually (MANF EVO) or by an electric motor ME (option and kit).

1. unlocking button
2. resetting handle
3. cable entrance

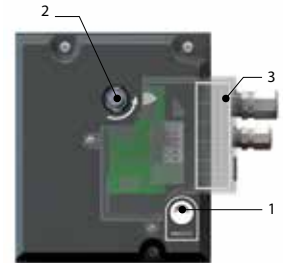

Options - at the time of order

VD24	Natural magnet 24 V DC + FDCU
VD48	Natural magnet 48 V DC + FDCU
VM24	Electromagnet 24 V DC + FDCU
VM48	Electromagnet 48 V DC + FDCU
FDCU	Limit switch 'open/closed'
FDCB	Auxiliary limit switch 'open/closed'
ME	Resetting motor ME 24V/48V

Unlocking

- **manual unlocking:** use the unlocking button (1).
- **automatic unlocking:** n/a
- **remote unlocking:** (option VD/VM MAN EVO FDCU) by sending an electrical impulse (VD) or by interrupting the power supply (VM) to the magnet's entrance.

Resetting

- **manual resetting:** turn 90° counter-clockwise with a hex socket wrench 13 mm (2).
- **motorised resetting:** (option ME MANF) switch off the power supply for at least 10 sec. Power the actuator for at least 30 sec. (respect the prescribed voltage and polarity). The resetting stops automatically if a torque > 20 Nm is detected.

Caution:

- ▲ Switch off the power supply after resetting.
- ▲ Switch off the power supply for at least 15 sec. in between each resetting cycle.

Caution:

- ▲ The mechanism may never be tested on its own, without being attached to the damper. Such a test might damage the mechanism or the operator might be injured.



NF Remotely controlled spring return actuator (for small dimensions)

The servomotor is designed to control smoke evacuation dampers from a distance. This solution is suitable in case of counter-pressure. Beginning and end of range switches included.

1. access for manual resetting
2. locking button

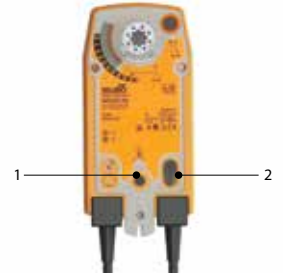

Unlocking

- **manual unlocking:** use the enclosed handle and turn 1/4 turn counter-clockwise; push the locking button to the left.
- **automatic unlocking:** n/a
- **remote unlocking:** by interrupting the power supply (for dampers with NF/SF-VD module: by sending an electrical impulse).

Caution:

- ⚠ If the power supply to the motor is interrupted, the blade of the damper opens.

Resetting

- **manual resetting:** use the enclosed handle and turn counterclockwise. To block the motor, push the locking button to the right.
- **motorised resetting:** switch off the power supply for at least 10 sec (3 sec for NF/SF-VD module). Supply the actuator (respect the prescribed voltage) for at least 180 sec. The resetting stops automatically when the end of range is reached (damper closed).

Caution:

- ⚠ Do not use a drill or screwing machine.
- ⚠ Stop as soon as the motor is completely reamed (end of range).

Caution:

- ⚠ The mechanism may never be tested on its own, without being attached to the damper. Such a test might damage the mechanism or the operator might be injured.



SF Remotely controlled spring return actuator (for large dimensions)

The servomotor is designed to control smoke evacuation dampers from a distance. This solution is suitable for use in case of counter-pressure. Beginning and end of range switches included.

1. access for manual resetting
2. locking button



Unlocking

- **manual unlocking:** use the enclosed handle and turn 1/4 turn counter-clockwise; push the locking button to the left.
- **automatic unlocking:** n/a
- **remote unlocking:** by interrupting the power supply (for dampers with NF/SF-VD module: by sending an electrical impulse).

Caution:

- ⚠ If the power supply to the motor is interrupted, the blade of the damper opens.

Resetting

- **manual resetting:** use the enclosed handle and turn counterclockwise. To block the motor, push the locking button to the right.
- **motorised resetting:** switch off the power supply for at least 10 sec (3 sec for NF/SF-VD module). Supply the actuator (respect the prescribed voltage) for at least 180 sec. The resetting stops automatically when the end of range is reached (damper closed).

Caution:

- ⚠ Do not use a drill or screwing machine.
- ⚠ Stop as soon as the motor is completely rearmed (end of range).

Caution:

- ⚠ The mechanism may never be tested on its own, without being attached to the damper. Such a test might damage the mechanism or the operator might be injured.



BLE Actuator for remote control of smoke control dampers

The actuator B(L)E is specially designed to remotely control smoke control dampers. The BLE model is intended for VU90-HOT dampers with small dimensions ($W+H < 1800$ mm) and for VU120 and VUW120 dampers.

1. access for manual resetting
2. plug (ST)



Unlocking

- **manual unlocking:** VUW120: turn the enclosed handle clockwise / VU120 - VU90-HOT: turn the enclosed handle anti-clockwise.
- **automatic unlocking:** n/a
- **remote unlocking:** power cables 1 and 2.

Caution:

⚠ Do not use a drill or screwing machine.

Resetting

- **manual resetting:** VUW120: turn the enclosed handle anti-clockwise / VU120 - VU90-HOT: turn the enclosed handle clockwise.
- **motorised resetting:** power cables 1 and 3.

Caution:

⚠ Do not use a drill or screwing machine.

Electrical connection

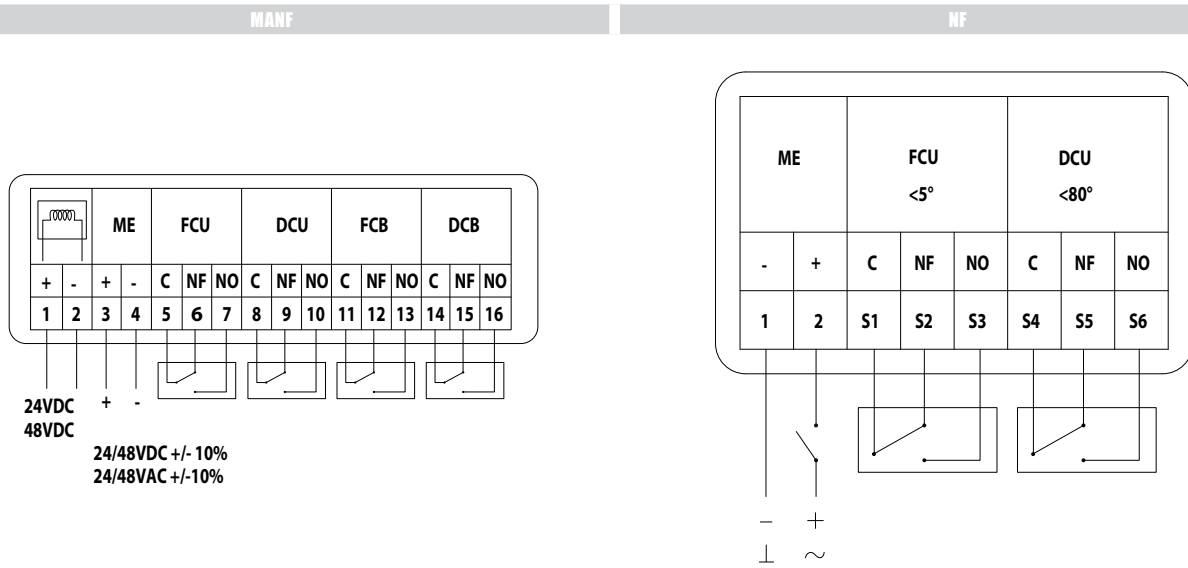

MEC	Nominal voltage motor	Nominal voltage magnet	Power consumption (stand-by)	Power consumption (operating)	Standard switches
MANF EVO	24 V DC / 24 V AC / 48 V DC / 48 V AC	24/48 V DC	VM: 1,5W / VD: - / ME: -	VD: 3,5W / ME: Pmax 20W (24V)/40W (48V)	1mA...1A, DC 5V...AC 48V
NF24	24 V AC/DC	N/A	2,5W	6W	1mA...3(0.5A),AC250V
NF230	230 V AC	N/A	2,5W	6W	1mA...3(0.5A),AC250V

MEC	Resetting time motor	Running time spring	Noise level motor	Noise level spring	Cable supply / control	Cable auxiliary switch	Protection class
MANF EVO	< 30 s	1 s	≤ 50 dB (A)	N/A			IP 42
NF24	< 60 s	20 s	≤ 45 dB (A)	ca. 63 dB (A)	1 m, 2 x 0.75 mm ² (halogen-free)	1 m, 6 x 0.75 mm ² (halogen-free)	IP 54
NF230	< 60 s	20 s	≤ 45 dB (A)	ca. 63 dB (A)	1 m, 2 x 0.75 mm ² (halogen-free)	1 m, 6 x 0.75 mm ² (halogen-free)	IP 54

Electrical connection

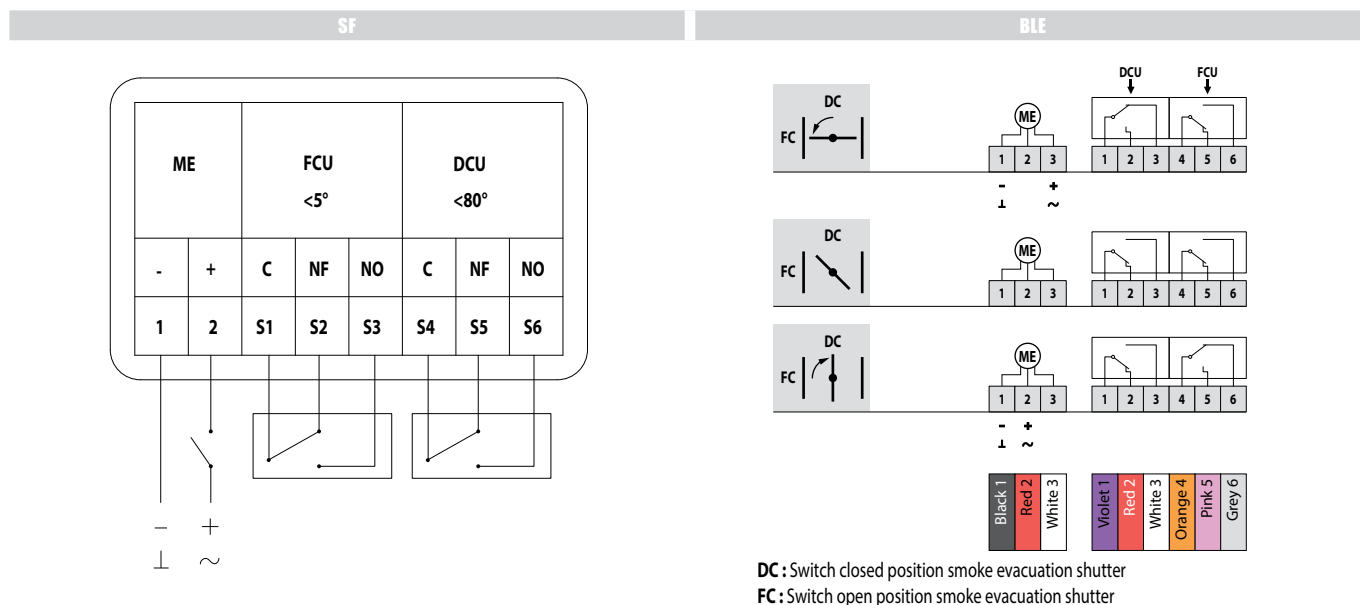

MEC	Nominal voltage motor	Nominal voltage magnet	Power consumption (stand-by)	Power consumption (operating)	Standard switches
SF24	24 V AC/DC	N/A	2,5W	5W	1mA...3(0.5A),AC250V
SF230	230 V AC	N/A	3,5W	6,5W	1mA...3(0.5A),AC250V
BLE24	24 V AC/DC	N/A	0,5W	7,5W	1mA...3A, DC 5V...AC 250V
BLE24-ST	24 V AC/DC	N/A	0,5W	7,5W	1mA...3A, DC 5V...AC 250V
BLE230	230 V AC	N/A	1W	5W	1mA...3A, DC 5V...AC 250V

MEC	Resetting time motor	Running time spring	Noise level motor	Noise level spring	Cable supply / control	Cable auxiliary switch	Protection class
SF24	< 60 s	20 s	≤ 45 dB (A)	ca. 63 dB (A)	1 m, 2 x 0.75 mm ² (halogen-free)	1 m, 6 x 0.75 mm ² (halogen-free)	IP 54
SF230	< 60 s	20 s	≤ 45 dB (A)	ca. 63 dB (A)	1 m, 2 x 0.75 mm ² (halogen-free)	1 m, 6 x 0.75 mm ² (halogen-free)	IP 54
BLE24	< 30 s (90°)	N/A	ca. 62 dB (A)		1 m, 3 x 0.75 mm ² (halogen-free)	1 m, 6 x 0.75 mm ² (halogen-free)	IP 54
BLE24-ST	< 30 s (90°)	N/A	ca. 62 dB (A)		1 m, 3 x 0.75 mm ² (halogen-free), with plug connectors, suitable for IXI-R1, IXI-R2(-230), BKNE230-24	1 m, 6 x 0.75 mm ² (halogen-free), with plug connectors, suitable for IXI-R1, IXI-R2(-230), BKNE230-24	IP 54
BLE230	< 30 s (90°)	N/A	ca. 62 dB (A)		1 m, 3 x 0.75 mm ² (halogen-free)	1 m, 6 x 0.75 mm ² (halogen-free)	IP 54

Weights

VU120 + MANF EVO

Hn\Wn [mm]		200	250	300	350	400	450	500	550	600	650	700	750	800	850	900	950	1000	1050	1100	1150	1200
200	kg	10,3	11,2	12,1	13,1	14,0	14,9	15,8	16,8	17,7	18,6	19,5	20,5	21,4	22,3	23,3	24,2	25,1	26,0	27,0	27,9	28,8
250	kg	11,1	12,1	13,1	14,1	15,1	16,1	17,1	18,1	19,1	20,1	21,1	22,1	23,1	24,1	25,1	26,0	27,0	28,0	29,0	30,0	31,0
300	kg	12,0	13,1	14,1	15,2	16,3	17,3	18,4	19,4	20,5	21,6	22,6	23,7	24,7	25,8	26,8	27,9	29,0	30,0	31,1	32,1	33,2
350	kg	12,9	14,0	15,2	16,3	17,4	18,5	19,6	20,8	21,9	23,0	24,1	25,3	26,4	27,5	28,6	29,8	30,9	32,0	33,1	34,3	35,4
400	kg	13,8	15,0	16,2	17,4	18,5	19,7	20,9	22,1	23,3	24,5	25,7	26,9	28,1	29,2	30,4	31,6	32,8	34,0	35,2	36,4	37,6
450	kg	14,7	15,9	17,2	18,4	19,7	20,9	22,2	23,4	24,7	26,0	27,2	28,5	29,7	31,0	32,2	33,5	34,7	36,0	37,2	38,5	39,8
500	kg	15,5	16,9	18,2	19,5	20,8	22,1	23,5	24,8	26,1	27,4	28,7	30,1	31,4	32,7	34,0	35,3	36,7	38,0	39,3	40,6	41,9
550	kg	16,4	17,8	19,2	20,6	22,0	23,3	24,7	26,1	27,5	28,9	30,3	31,7	33,0	34,4	35,8	37,2	38,6	40,0	41,4	42,7	44,1
600	kg	17,3	18,8	20,2	21,7	23,1	24,6	26,0	27,5	28,9	30,4	31,8	33,3	34,7	36,2	37,6	39,1	40,5	42,0	43,4	44,9	46,3
650	kg	18,2	19,7	21,2	22,7	24,2	25,8	27,3	28,8	30,3	31,8	33,3	34,9	36,4	37,9	39,4	40,9	42,4	43,9	45,5	47,0	48,5
700	kg	19,1	20,6	22,2	23,8	25,4	27,0	28,5	30,1	31,7	33,3	34,9	36,5	38,0	39,6	41,2	42,8	44,4	45,9	47,5	49,1	50,7
750	kg	19,9	21,6	23,2	24,9	26,5	28,2	29,8	31,5	33,1	34,8	36,4	38,0	39,7	41,3	43,0	44,6	46,3	47,9	49,6	51,2	52,9
800	kg	20,8	22,5	24,2	26,0	27,7	29,4	31,1	32,8	34,5	36,2	37,9	39,6	41,4	43,1	44,8	46,5	48,2	49,9	51,6	53,3	55,0
850	kg	21,7	23,5	25,3	27,0	28,8	30,6	32,4	34,1	35,9	37,7	39,5	41,2	43,0	44,8	46,6	48,4	50,1	51,9	53,7	55,5	
900	kg	22,6	24,4	26,3	28,1	30,0	31,8	33,6	35,5	37,3	39,2	41,0	42,8	44,7	46,5	48,4	50,2	52,1	53,9	55,7		
950	kg	23,5	25,4	27,3	29,2	31,1	33,0	34,9	36,8	38,7	40,6	42,5	44,4	46,3	48,3	50,2	52,1	54,0	55,9			
1000	kg	24,3	26,3	28,3	30,3	32,2	34,2	36,2	38,2	40,1	42,1	44,1	46,0	48,0	50,0	52,0	53,9	55,9				

VU120 + NF24 / + NF230

Hn\Wn [mm]		200	250	300	350	400	450	500	550	600	650	700	750	800	850	900	950	1000	1050	1100	1150	1200
200	kg	10,9	11,8	12,7	13,7	14,6	15,5	16,4	17,4	18,3	19,2	20,1	21,1	22,0	22,9	23,9	24,8	25,7	26,6	27,6	28,5	29,4
250	kg	11,7	12,7	13,7	14,7	15,7	16,7	17,7	18,7	19,7	20,7	21,7	22,7	23,7	24,7	25,7	26,6	27,6	28,6	29,6	30,6	31,6
300	kg	12,6	13,7	14,7	15,8	16,9	17,9	19,0	20,0	21,1	22,2	23,2	24,3	25,3	26,4	27,4	28,5	29,6	30,6	31,7	32,7	33,8
350	kg	13,5	14,6	15,8	16,9	18,0	19,1	20,2	21,4	22,5	23,6	24,7	25,9	27,0	28,1	29,2	30,4	31,5	32,6	33,7	34,9	36,0
400	kg	14,4	15,6	16,8	18,0	19,1	20,3	21,5	22,7	23,9	25,1	26,3	27,5	28,7	29,8	31,0	32,2	33,4	34,6	35,8	37,0	38,2
450	kg	15,3	16,5	17,8	19,0	20,3	21,5	22,8	24,0	25,3	26,6	27,8	29,1	30,3	31,6	32,8	34,1	35,3	36,6	37,8	39,1	40,4
500	kg	16,1	17,5	18,8	20,1	21,4	22,7	24,1	25,4	26,7	28,0	29,3	30,7	32,0	33,3	34,6	35,9	37,3	38,6	-	-	-
550	kg	17,0	18,4	19,8	21,2	22,6	23,9	25,3	26,7	28,1	29,5	30,9	32,3	33,6	35,0	-	-	-	-	-	-	-
600	kg	17,9	19,4	20,8	22,3	23,7	25,2	26,6	28,1	29,5	31,0	32,4	33,9	-	-	-	-	-	-	-	-	-
650	kg	18,8	20,3	21,8	23,3	24,8	26,4	27,9	29,4	30,9	-	-	-	-	-	-	-	-	-	-	-	-
700	kg	19,7	21,2	22,8	24,4	26,0	27,6	29,1	30,7	-	-	-	-	-	-	-	-	-	-	-	-	-
750	kg	20,5	22,2	23,8	25,5	27,1	28,8	-	-	-	-	-	-	-	-	-	-	-	-	-	-	-
800	kg	-	-	-	-	-	-	-	-	-	-	-	-	-	-	-	-	-	-	-	-	-
850	kg	-	-	-	-	-	-	-	-	-	-	-	-	-	-	-	-	-	-	-	-	-
900	kg	-	-	-	-	-	-	-	-	-	-	-	-	-	-	-	-	-	-	-	-	-
950	kg	-	-	-	-	-	-	-	-	-	-	-	-	-	-	-	-	-	-	-	-	-
1000	kg	-	-	-	-	-	-	-	-	-	-	-	-	-	-	-	-	-	-	-	-	-

VU120 + SF24 / + SF230

Hn\Wn [mm]		200	250	300	350	400	450	500	550	600	650	700	750	800	850	900	950	1000	1050	1100	1150	1200
500	kg	-	-	-	-	-	-	-	-	-	-	-	-	-	-	-	-	-	-	40,2	41,5	42,8
550	kg	-	-	-	-	-	-	-	-	-	-	-	-	-	-	36,7	38,1	39,5	40,9	42,3	43,6	45,0
600	kg	-	-	-	-	-	-	-	-	-	-	-	-	35,6	37,1	38,5	40,0	41,4	42,9	44,3	45,8	47,2
650	kg	-	-	-	-	-	-	-	-	-	32,7	34,2	35,8	37,3	38,8	40,3	41,8	43,3	44,8	46,4	47,9	49,4
700	kg	-	-	-	-	-	-	-	-	32,6	34,2	35,8	37,4	38,9	40,5	42,1	43,7	45,3	46,8	-	-	-
750	kg	-	-	-	-	-	-	30,7	32,4	34,0	35,7	37,3	38,9	40,6	42,2	43,9	45,5	-	-	-	-	-

VU120 + BLE24 / + BLE24-ST / + BLE230

Hn\Wn (mm)		200	250	300	350	400	450	500	550	600	650	700	750	800	850	900	950	1000	1050	1100	1150	1200
200	kg	10,9	11,8	12,7	13,7	14,6	15,5	16,4	17,4	18,3	19,2	20,1	21,1	22,0	22,9	23,9	24,8	25,7	26,6	27,6	28,5	29,4
250	kg	11,7	12,7	13,7	14,7	15,7	16,7	17,7	18,7	19,7	20,7	21,7	22,7	23,7	24,7	25,7	26,6	27,6	28,6	29,6	30,6	31,6
300	kg	12,6	13,7	14,7	15,8	16,9	17,9	19,0	20,0	21,1	22,2	23,2	24,3	25,3	26,4	27,4	28,5	29,6	30,6	31,7	32,7	33,8
350	kg	13,5	14,6	15,8	16,9	18,0	19,1	20,2	21,4	22,5	23,6	24,7	25,9	27,0	28,1	29,2	30,4	31,5	32,6	33,7	34,9	36,0
400	kg	14,4	15,6	16,8	18,0	19,1	20,3	21,5	22,7	23,9	25,1	26,3	27,5	28,7	29,8	31,0	32,2	33,4	34,6	35,8	37,0	38,2
450	kg	15,3	16,5	17,8	19,0	20,3	21,5	22,8	24,0	25,3	26,6	27,8	29,1	30,3	31,6	32,8	34,1	35,3	36,6	37,8	39,1	40,4
500	kg	16,1	17,5	18,8	20,1	21,4	22,7	24,1	25,4	26,7	28,0	29,3	30,7	32,0	33,3	34,6	35,9	37,3	38,6	39,9	41,2	42,5
550	kg	17,0	18,4	19,8	21,2	22,6	23,9	25,3	26,7	28,1	29,5	30,9	32,3	33,6	35,0	36,4	37,8	39,2	40,6	42,0	43,3	44,7
600	kg	17,9	19,4	20,8	22,3	23,7	25,2	26,6	28,1	29,5	31,0	32,4	33,9	35,3	36,8	38,2	39,7	41,1	42,6	44,0	45,5	46,9
650	kg	18,8	20,3	21,8	23,3	24,8	26,4	27,9	29,4	30,9	32,4	33,9	35,5	37,0	38,5	40,0	41,5	43,0	44,5	46,1	47,6	49,1
700	kg	19,7	21,2	22,8	24,4	26,0	27,6	29,1	30,7	32,3	33,9	35,5	37,1	38,6	40,2	41,8	43,4	45,0	46,5	48,1	49,7	51,3
750	kg	20,5	22,2	23,8	25,5	27,1	28,8	30,4	32,1	33,7	35,4	37,0	38,6	40,3	41,9	43,6	45,2	46,9	48,5	50,2	51,8	53,5
800	kg	21,4	23,1	24,8	26,6	28,3	30,0	31,7	33,4	35,1	36,8	38,5	40,2	42,0	43,7	45,4	47,1	48,8	50,5	52,2	53,9	55,6
850	kg	22,3	24,1	25,9	27,6	29,4	31,2	33,0	34,7	36,5	38,3	40,1	41,8	43,6	45,4	47,2	49,0	50,7	52,5	54,3	56,1	
900	kg	23,2	25,0	26,9	28,7	30,6	32,4	34,2	36,1	37,9	39,8	41,6	43,4	45,3	47,1	49,0	50,8	52,7	54,5	56,3		
950	kg	24,1	26,0	27,9	29,8	31,7	33,6	35,5	37,4	39,3	41,2	43,1	45,0	46,9	48,9	50,8	52,7	54,6	56,5			
1000	kg	24,9	26,9	28,9	30,9	32,8	34,8	36,8	38,8	40,7	42,7	44,7	46,6	48,6	50,6	52,6	54,5	56,5				

Selection data

$$\Delta p = 0,6 \times v^2 \times \zeta$$

Hn\Wn (mm)		200	250	300	350	400	450	500	550	600	650	700	750	800	850	900	950	1000	1050	1100	1150	1200
200	ζ [-]	1,71	1,43	1,24	1,1	1	0,92	0,85	0,79	0,74	0,7	0,66	0,63	0,6	0,58	0,56	0,53	0,52	0,5	0,48	0,47	0,45
250	ζ [-]	1,4	1,17	1,02	0,9	0,82	0,75	0,69	0,65	0,61	0,57	0,54	0,52	0,49	0,47	0,45	0,44	0,42	0,41	0,39	0,38	0,37
300	ζ [-]	1,21	1,01	0,87	0,78	0,7	0,64	0,59	0,55	0,52	0,49	0,46	0,44	0,42	0,4	0,39	0,37	0,36	0,35	0,34	0,33	0,32
350	ζ [-]	1,06	0,89	0,77	0,68	0,62	0,57	0,52	0,49	0,46	0,43	0,41	0,39	0,37	0,36	0,34	0,33	0,32	0,31	0,3	0,29	0,28
400	ζ [-]	0,96	0,8	0,69	0,61	0,56	0,51	0,47	0,44	0,41	0,39	0,37	0,35	0,33	0,32	0,31	0,3	0,29	0,28	0,27	0,26	0,25
450	ζ [-]	0,87	0,73	0,63	0,56	0,51	0,46	0,43	0,4	0,38	0,35	0,34	0,32	0,3	0,29	0,28	0,27	0,26	0,25	0,24	0,24	0,23
500	ζ [-]	0,81	0,67	0,58	0,52	0,47	0,43	0,4	0,37	0,35	0,33	0,31	0,29	0,28	0,27	0,26	0,25	0,24	0,23	0,22	0,22	0,21
550	ζ [-]	0,75	0,62	0,54	0,48	0,43	0,4	0,37	0,34	0,32	0,3	0,29	0,27	0,26	0,25	0,24	0,23	0,22	0,22	0,21	0,2	0,2
600	ζ [-]	0,7	0,59	0,51	0,45	0,41	0,37	0,34	0,32	0,3	0,28	0,27	0,26	0,24	0,23	0,22	0,22	0,21	0,2	0,19	0,19	0,16
650	ζ [-]	0,66	0,55	0,48	0,42	0,38	0,35	0,32	0,3	0,28	0,27	0,25	0,24	0,23	0,22	0,21	0,2	0,2	0,19	0,18	0,18	0,17
700	ζ [-]	0,63	0,52	0,45	0,4	0,36	0,33	0,31	0,29	0,27	0,25	0,24	0,23	0,22	0,21	0,2	0,19	0,19	0,18	0,17	0,17	0,16
750	ζ [-]	0,6	0,5	0,43	0,38	0,34	0,32	0,29	0,27	0,25	0,24	0,23	0,22	0,21	0,2	0,19	0,18	0,18	0,17	0,16	0,16	0,16
800	ζ [-]	0,57	0,47	0,41	0,36	0,33	0,3	0,28	0,26	0,24	0,23	0,22	0,21	0,2	0,19	0,18	0,17	0,17	0,16	0,16	0,15	0,15
850	ζ [-]	0,54	0,45	0,39	0,35	0,31	0,29	0,27	0,25	0,23	0,22	0,21	0,2	0,19	0,18	0,17	0,17	0,16	0,16	0,15	0,15	
900	ζ [-]	0,52	0,43	0,38	0,33	0,3	0,28	0,25	0,24	0,22	0,21	0,2	0,19	0,18	0,17	0,17	0,16	0,15	0,15	0,14		
950	ζ [-]	0,5	0,42	0,36	0,32	0,29	0,27	0,25	0,23	0,21	0,2	0,19	0,18	0,17	0,17	0,16	0,15	0,15	0,14			
1000	ζ [-]	0,48	0,4	0,35	0,31	0,28	0,26	0,24	0,22	0,21	0,19	0,18	0,18	0,17	0,16	0,15	0,15	0,14				

VU120 - Free air passage (m²)

Hn\Wn (mm)		200	250	300	350	400	450	500	550	600	650	700
200	Sn [m ²]	0,0244	0,0313	0,0382	0,0451	0,0520	0,0588	0,0657	0,0726	0,0795	0,0864	0,0932
250	Sn [m ²]	0,0330	0,0423	0,0517	0,0611	0,0705	0,0798	0,0892	0,0986	0,1080	0,1174	0,1267
300	Sn [m ²]	0,0415	0,0533	0,0652	0,0771	0,0890	0,1009	0,1127	0,1246	0,1365	0,1484	0,1602
350	Sn [m ²]	0,0500	0,0644	0,0787	0,0931	0,1075	0,1219	0,1362	0,1506	0,1650	0,1794	0,1938
400	Sn [m ²]	0,0585	0,0754	0,0922	0,1091	0,1260	0,1429	0,1597	0,1766	0,1935	0,2104	0,2273
450	Sn [m ²]	0,0670	0,0864	0,1057	0,1251	0,1445	0,1639	0,1833	0,2026	0,2220	0,2414	0,2608
500	Sn [m ²]	0,0755	0,0974	0,1193	0,1411	0,1630	0,1849	0,2068	0,2286	0,2505	0,2724	0,2943
550	Sn [m ²]	0,0840	0,1084	0,1328	0,1571	0,1815	0,2059	0,2303	0,2547	0,2790	0,3034	0,3278
600	Sn [m ²]	0,0925	0,1194	0,1463	0,1731	0,2000	0,2269	0,2538	0,2807	0,3075	0,3344	0,3613
650	Sn [m ²]	0,1010	0,1304	0,1598	0,1892	0,2185	0,2479	0,2773	0,3067	0,3360	0,3654	0,3948
700	Sn [m ²]	0,1095	0,1414	0,1733	0,2052	0,2370	0,2689	0,3008	0,3327	0,3646	0,3964	0,4283
750	Sn [m ²]	0,1180	0,1524	0,1868	0,2212	0,2555	0,2899	0,3243	0,3587	0,3931	0,4274	0,4618
800	Sn [m ²]	0,1265	0,1634	0,2003	0,2372	0,2741	0,3109	0,3478	0,3847	0,4216	0,4584	0,4953
850	Sn [m ²]	0,1351	0,1744	0,2138	0,2532	0,2926	0,3319	0,3713	0,4107	0,4501	0,4895	0,5288
900	Sn [m ²]	0,1436	0,1854	0,2273	0,2692	0,3111	0,3530	0,3948	0,4367	0,4786	0,5205	0,5623
950	Sn [m ²]	0,1521	0,1964	0,2408	0,2852	0,3296	0,3740	0,4183	0,4627	0,5071	0,5515	0,5958
1000	Sn [m ²]	0,1606	0,2075	0,2543	0,3012	0,3481	0,3950	0,4418	0,4887	0,5356	0,5825	0,6294

Hn\Wn (mm)		750	800	850	900	950	1000	1050	1100	1150	1200	
200	Sn [m ²]	0,1001	0,1070	0,1139	0,1207	0,1276	0,1345	0,1414	0,1483	0,1551	0,1620	
250	Sn [m ²]	0,1361	0,1455	0,1549	0,1642	0,1736	0,1830	0,1924	0,2018	0,2111	0,2205	
300	Sn [m ²]	0,1721	0,1840	0,1959	0,2078	0,2196	0,2315	0,2434	0,2553	0,2671	0,2790	
350	Sn [m ²]	0,2081	0,2225	0,2369	0,2513	0,2656	0,2800	0,2944	0,3088	0,3232	0,3375	
400	Sn [m ²]	0,2441	0,2610	0,2779	0,2948	0,3117	0,3285	0,3454	0,3623	0,3792	0,3960	
450	Sn [m ²]	0,2801	0,2995	0,3189	0,3383	0,3577	0,3770	0,3964	0,4158	0,4352	0,4545	
500	Sn [m ²]	0,3162	0,3380	0,3599	0,3818	0,4037	0,4255	0,4474	0,4693	0,4912	0,5131	
550	Sn [m ²]	0,3522	0,3765	0,4009	0,4253	0,4497	0,4741	0,4984	0,5228	0,5472	0,5716	
600	Sn [m ²]	0,3882	0,4150	0,4419	0,4688	0,4957	0,5226	0,5494	0,5763	0,6032	0,6301	
650	Sn [m ²]	0,4242	0,4536	0,4829	0,5123	0,5417	0,5711	0,6004	0,6298	0,6592	0,6886	
700	Sn [m ²]	0,4602	0,4921	0,5239	0,5558	0,5877	0,6196	0,6515	0,6833	0,7152	0,7471	
750	Sn [m ²]	0,4962	0,5306	0,5650	0,5993	0,6337	0,6681	0,7025	0,7368	0,7712	0,8056	
800	Sn [m ²]	0,5322	0,5691	0,6060	0,6428	0,6797	0,7166	0,7535	0,7903	0,8272	0,8641	
850	Sn [m ²]	0,5682	0,6076	0,6470	0,6863	0,7257	0,7651	0,8045	0,8439	0,8832		
900	Sn [m ²]	0,6042	0,6461	0,6880	0,7299	0,7717	0,8136	0,8555	0,8974			
950	Sn [m ²]	0,6402	0,6846	0,7290	0,7734	0,8177	0,8621	0,9065				
1000	Sn [m ²]	0,6762	0,7231	0,7700	0,8169	0,8637	0,9106					

Approvals and certificates

All our products are submitted to a number of tests by official test institutes. Reports of these tests form the basis for the approvals of the products.



Efectis - 1812-CPR-1595



18.28

NF 537
CLAPETS RÉSISTANT AU FEU
VOLETS RÉSISTANT AU FEU
www.marque-nf.com

The NF-label guarantees: conformity with the standard NF S 61-937 Parts 1 and 10: "Systèmes de Sécurité Incendie Dispositifs Actionnés de Sécurité"; conformity with the national decree of March 22, 2004, changed on 14 March 2011 for the classification of fire resistance; the values of the characteristics mentioned in this document. Organisme Certificateur: AFNOR Certification, 11 Rue Francis de Pressensé, F93571 La Plaine Saint-Denis Cedex; Website: <http://www.afnor.org> <http://www.marque-nf.com>; Phone: +33 (0)1.41.62.80.00, Fax: +33 (0)1.49.17.90.00, Email: certification@afnor.org

If the product is manipulated in any other way than described in this manual, Rf-Technologies will decline any responsibility and the guarantee will expire!

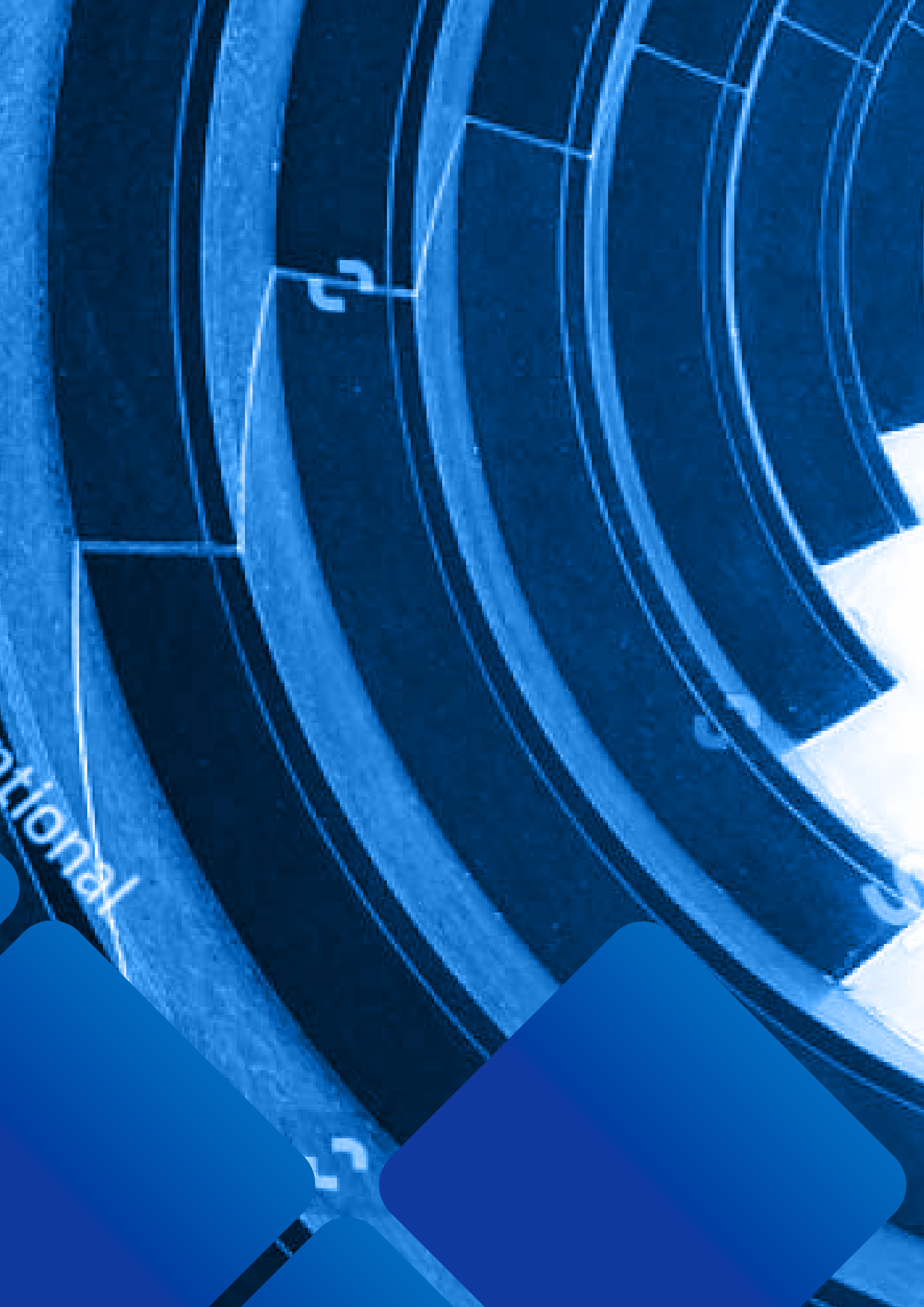

ational

20

AMS/Rf-t Partnership



AMS Air Movement Supplies has teamed up with **Rf-Technologies**, one of the largest manufacturers in Europe, to promote their extensive range of CE marked fire and smoke rated dampers.

The company employs 170 people in its two sites in Belgium (headquarters) and Slovakia. **Rf-Technologies** solutions are designed and approved for all types of walls: vertical and horizontal, in concrete or lightweight materials. They are compliant with the most stringent local and European standards. In its pioneering role in the field of compliance with international standards, **Rf-Technologies** has been testing its products according to the European test criteria since 2004.

This union of resources between **AMS** and **Rf-t** will offer more choice than any other supplier or distributor in Ireland and the UK. **Rf-t** are the first to bring intelligent motors to the Irish market, eliminating the need for an additional field module. Its wiring, along with many other progressive features, has erased the need for costly engineers.

For any queries, please contact us at sales@airmovementsupplies.ie.

AMS Air Movement Supplies,
Unit 23, Second Avenue, Cookstown Ind. Est.,
Tallaght, Dublin 24, D24 FP95, Ireland.

Ph: +353 1 463 4300

Email: info@airmovementsupplies.ie

www.airmovementsupplies.ie

AMS
AIR MOVEMENT SUPPLIES

TRUSTED PARTNER OF



Rf-Technologies

*"Individually, we are one drop.
Together, we are an ocean."*

— Ryunosuke Satoro

